

## SD12 Multi-Circuit Single Phase Ground Fault Monitor

### FEATURES

- Ground fault protection for resistance and solidly grounded single-phase systems
- Ground-fault protection on single-phase systems
- Microprocessor based - recalibration not required
- 12 channels input with residual current CT inside
- Can be optionally extended to 16 channels
- Adjustable sensitivity from 10 mA to 3.0 A to reduce nuisance trips
- Self-test function
- Remote reset and indication
- Modbus/RTU protocol over RS485 data communication port
- Alarm supervision display module
- DIN-rail mounting for main measurement module
- Panel mounting for supervision display module
- Designed to monitor and detect ground fault currents using on board CT
- Alarm supervision LED display shows alarm as well as various user settings
- Microprocessor controlled with internal monitoring (self checking)
- Single button operation for test/reset
- Facility for remote operation



### BACKGROUND

It is estimated that more than 85% of short circuits are initially manifested as ground faults (also known as earth leakage or residual current). Detection of these faults before they reach hazardous levels can help to avoid damage to process equipment and increase personnel safety. This allows preventive maintenance before costly damage occurs which in turn minimizes costly downtime.

### DESCRIPTION

The SD-12 is a microprocessor-based, multi-circuit, single-phase, ground-fault monitor for resistance grounded and solidly grounded electrical systems. The module is equipped with on-board residual current sensors which eliminates the need for installing additional CT sensors. The SD-12 features a front panel LED and self test capabilities.

Ground faults are often inevitable, but the SD-12 offers a means of quickly neutralizing the problem, saving you from its costly and dangerous consequences.

As soon as a piece of equipment being monitored by the SD-12 is detected to have a ground fault situation above a preset level, the LED will light up and the contacts will be activated. The Modbus/RTU over RS485 communication interface can be used to signal an automation system (such as a PLC) or it can be used for direct control of an alarm or even the equipment that it is monitoring (via the magnetic contactor). This permits the maintenance personnel to locate the problematic equipment even if the problem is of an intermittent nature.



**SPECIFICATION**

**Main Module**

Supply	120 Vac or 220 Vac, 50/60 Hz, 3.5 VA
Input Range	20A
Sensitivity Setting Range	High: 5 mA , Low: 8 mA
ZCT Internal Diameter	6.5mm
Ground-Fault Setting	Level: $5 \pm 0.9$ mA
LED Indicator	The abnormal channel number
Data Communication	Modbus/RTU protocol over RS485
Operating Temperature	-40°C to 70°C
Storage Temperature	-55°C to 80°C
Relative Humidity	85% Non-condensing
Surge Withstand	ANSI/IEEE 37.90.1-1989 (Oscillatory and Fast Transient)

**Supervisor Module**

Supply	No power supply required, power obtained directly from main module
Test Button	For initial test
LED	16 LEDs indicate the abnormal condition
Max Distance From Main Module	50 cm

**DIMENSIONS**

**Main module**

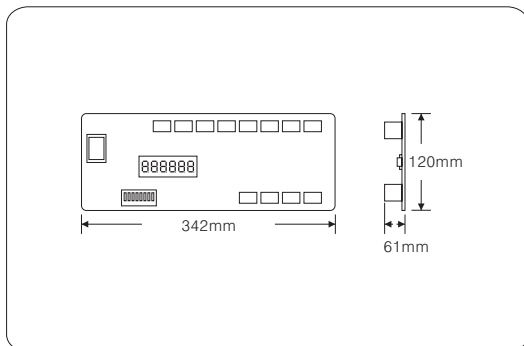

**Supervisor Module**

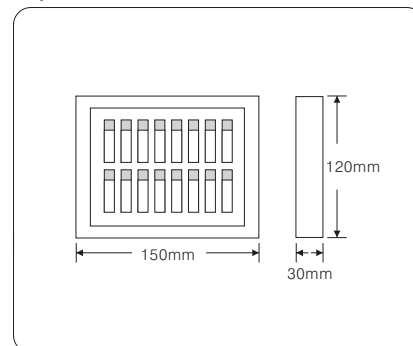

**DAE INSTRUMENT CORP.**

8F., No.1, Singnan St., Nangang District, Taipei City 115, Taiwan (R.O.C.) Tel: +886-2-26546203 Fax: +886-2-26547697

Our Website: [www.daeinstrument.com.tw](http://www.daeinstrument.com.tw)